

SKF 薄膜行业授权经销商
薄膜行业专用备件供应商



联系方式

地址: 浙江省绍兴市越城区斗门街道群贤中路 1210 号
友邦智创科技园 7 号楼

电话: 0575 8804 6705

传真: 0575 8804 1081

联系人: 王德成 13957589805



CONTACT

Name: Youbang Zhichuang Science and Technology Park, No.1210, Quxian Middle Road,
Doumen Sub-district, Yuecheng District, Shaoxing City, Zhejiang Province

Telephone: +86 575 8804 6705

Fax: +86 575 8804 1081

Contact person: wangdecheng 13957589805



绍兴涌泉机电物资有限公司



01 公司简介

- 01 公司简介
- 03 工作环境
- 07 合作伙伴



09 优势项目

- 09 链条翻新服务
- 11 链条翻新前后效果
- 13 SKF 轴承薄膜行业代理商
- 14 SKF 产品在生产线上的应用
- 15 SKF 在 TDO 链夹轴承
- 16 Pulse 便携式点巡检终端
- 17 TLDD 数字化机电式单点自动润滑器
- 18 BOPET 生产线的专用触媒及服务

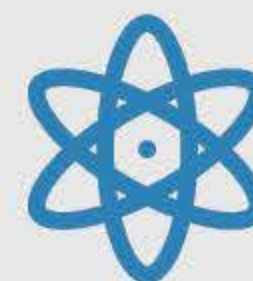

19 核心产品

- 19 静电丝 静电钢带
- 20 铜丝棉 铜丝网
- 21 TDO 宽幅计数器
- 22 静电钢丝钢带收放卷装置
- 23 BOPET 生产线 TDO 余热回收
- 25 联合开发红外管
- 26 安徽煜卓机械简介
- 27 薄膜破碎机主轴转子修复



29 配件



涌泉机电成立于 2008 年，是一家全方位提供双拉生产线备件的行业知名企业。本公司主要人员在双向拉伸行业从业多年，有丰富的设备管理经验和备件直供渠道。产业常用配件本公司常年备货齐全，可以为德国布鲁克纳、德国多尼尔、日本三菱、法国 DMT 等主线设备及阿托拉斯分切机、康普分切机、阿尔泰克造粒机、埃尔马造粒机等配套设备提供优质易损配件。

其中 BOPET 生产线的专用易耗件静电吸附丝 / 静电吸附带为本公司的特有成熟产品，市场占有率超 70%。本公司自 2022 年起成为 SKF 全系列产品在薄膜行业授权代理商，TDO 链夹轴承、生产线通用轴承我们常年备有库存，方便各膜厂。2016 年始我们与德国克莱恩公司合作共同推广 TDO 触媒项目，该触媒为布鲁克纳生产线标配项目，本公司现已在国内成功取得多家薄膜厂合作项目。

经过多年的研究、设计、试验与实践，从 2019 年起我们推出了 TDO 链条链夹的翻新服务，从解体、清洗到组装，我们设计了全套的工装和流程，而且已在多条生产线上正常高质使用。我们可以提供链条链夹的全套易损件，完美替代进口配件；对没有链条链夹备件的膜厂，我们可以提供现场服务。此外公司备有 TDO 整线链条一套，可以提供链条租赁业务。

我们公司同时可以为薄膜厂家提供设备大修服务及生产线改造服务，如产线节能改造、功能升级改造等。

Yongquan Electromechanical Material Co., Ltd is located in Shaoxing, Zhejiang Province, 200km southwest to Shanghai. Established in 2008, the company has been committed to the machinery supplement for BoPT industry. Our personnel have gained years of working experience pertaining to technical and managing positions in BoPT manufacturers, highly proficient in equipment management, extensively skilled in device maintenance and well versed in supply chains. We have acquired strong reputation for high-quality products with competitive price among more than 100 clients nationwide, offering a variety of machinery and parts for main equipment including Brückner, Dornier, Mitsubishi, DMT S.A., and consumable accessories for supporting facilities including Altas slitter, KAMPF slitter, ARTEC granulator, EREMA granulator etc.

Among them, one of our star products is the static dissipating belting for BOPET, with a market share of over 80% in China. Since 2022 the company has become SKF products in the film industry authorized agents, TDO chain clamp bearings, general-purpose bearings production line we will do adequate inventory, convenient for the film factory. In 2016, Klein took the initiative to cooperate with us to promote the TDO catalyst project, and we have successfully obtained a number of factory cooperation projects in China.

After years of research, design, experimentation and practice, we have launched refurbishment service for TDO chain clamps starting in 2019. We have designed a complete set of tooling and processes from disassembly, cleaning to assembly. We can provide a full set of TDO chains or any spare parts for chain clamps, which can perfectly replace the original imported accessories at a competitive price. The entire chain designed and manufactured by us has been used in high quality on many production lines. In addition, we provide on-site service and chain leasing business.

Our company can also provide film manufacturers with equipment overhaul services and production line transformation services, such as energy-saving transformation, functional upgrading transformation.

仓库



企业荣誉

办公环境





车间

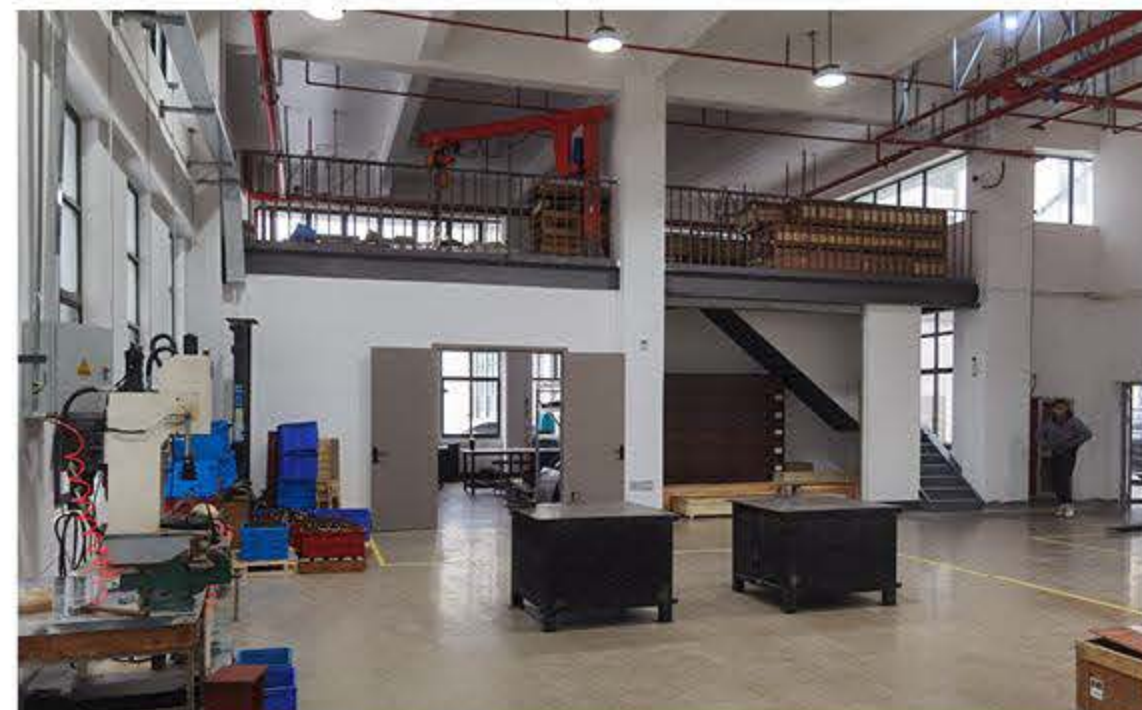

我们的客户

现和我们合作双向拉伸膜企 300+, 遍布全国 BOPET, BOPP, BOPA 等 90% 以上客户, 合作粘度高。

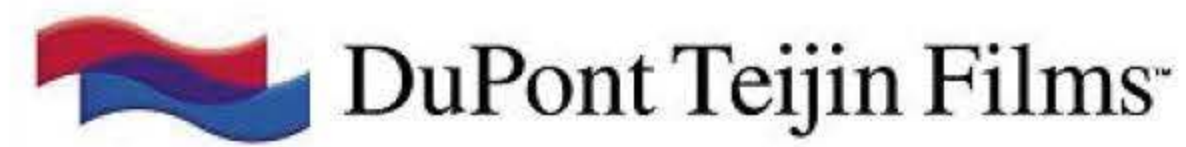

链条翻新服务

设计了全套的工装和流程

经过多年研究、设计、试验与实践，从 2019 年开始我们隆重推出 TDO 链条链夹的翻新服务，从解体、清洗、到组装设计了全套工装，规范作业。同时优化了整个作业流程。

极具市场竞争力的价格

我们可以提供整条 TDO 链条及链条链夹全套易损件，以极具市场竞争力的价格优势完美替代原装进口线配件。由我们设计制造的整条链条已在多条生产线上正常高质使用。

提供现场服务及链条租赁

对于没有链条链夹整套备件的，我们可以提供现场服务。此外本公司还备有一条 TDO 整线链条一套，可以提供链条租赁业务。

目前我公司提供的链条、链夹组件自制部分的备品备件。其精度、强度已达到与进口原件无差别化互换的水平。加工精度链节、链片都控制在 0.015mm 之内。销轴径向 0.006mm 之内。

材料方面：与外企合作共同开发，链节是精密铸造，链片是模锻。材料经多次热处理。全面探伤，拉伸强度试验，确保各项物理性能指标等于或高于原装件。外购的标准件，一律采用业内知名品牌原装进口，如衬套、轴承、弹簧、O 型圈等。



链条翻新前后效果

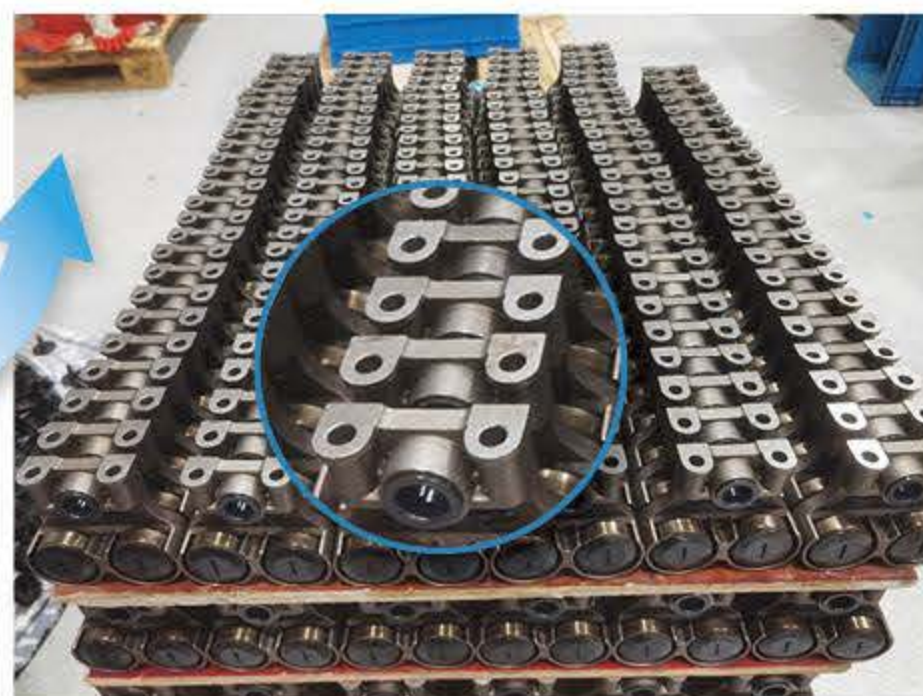

·翻新前·

·翻新后·

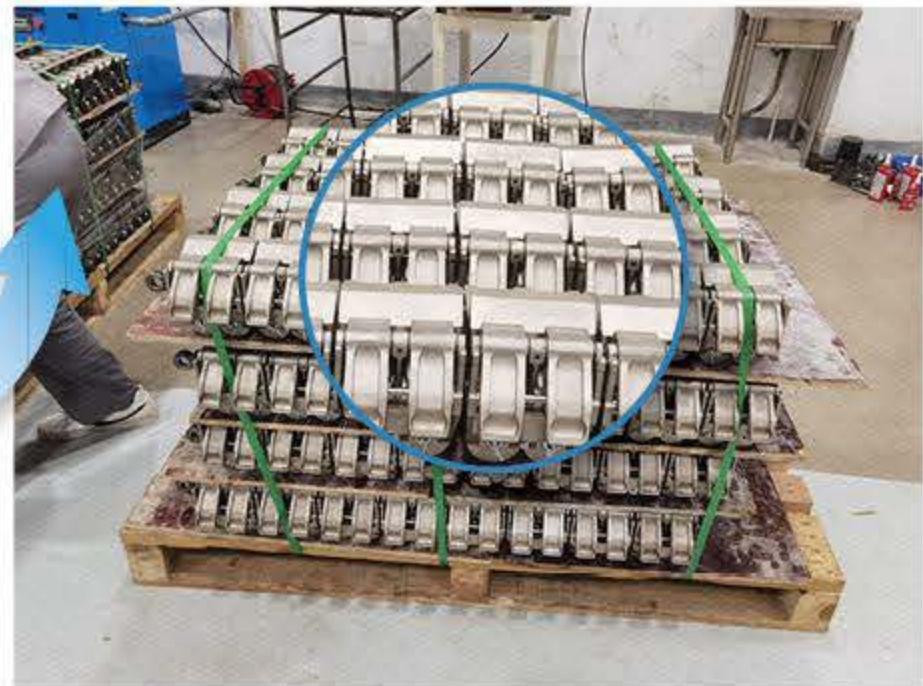

·翻新前·

·翻新后·

II SKF 轴承薄膜行业代理商

我们公司已于 2022 年 11 月取得 SKF 在塑料薄膜行业合作伙伴授权，我们将与 SKF 集团一起共同推进 SKF 全系列产品在整个塑料薄膜行业健康有续发展。



斯凯孚行业大客户经销商

兹授权
绍兴涌泉机电物资有限公司

为斯凯孚(中国)销售有限公司
塑料薄膜制造行业大客户经销商

SKF 行业经销商

周洁
斯凯孚中国区副总裁

证书编号: SKA-ZJK4
授权范围: 中国大陆地区塑料薄膜制造行业
产品范围: SKF 工业全系列产品
证书有效期: 2025年1月1日-2025年12月31日, 受《斯凯孚授权合作伙伴合同》的约束。

本证书原件文件有效
本证书真伪可通过扫描下方二维码验证:
关注“斯凯孚中国SKF”微信公众号, 点击“商家服务”>“防伪求真”>“SKF授权合作伙伴鉴别”后扫码或输入证书编号。





II SKF 产品在生产线上的应用



II SKF 在 TDO 链夹轴承

该链夹轴承是 SKF 为薄膜生产设备所专门开发，现为多尼尔、DMT 等薄膜设备生产厂商所指定专门品牌，同时也可为布鲁克纳、制钢所、东丽等生产线维修配套，及国内高端设备制造商选用。

零漏脂及在高温环境下的高可靠性，是客户选择 SKF 链夹轴承的重要原因。



· SKF 零泄漏的密封结构

在工作温度为 150~250° C 的工作环境下，高可靠性的密封材料及结构，同时 SKF 专利的热处理技术，保证了链夹轴承长期稳定运行！！

某 BOPE 使用经验对比（寿命 / 年）



SKF 某竞争品牌

· 典型轴承配置

- 6202 OD40
- 6202 OD42
- 6201 OD35

II Pulse 便携式点巡检终端



速度
加速度包络
温度测量

· 让设备监测变得简单

- 易于使用的便携式传感器和免费的移动 app
- 易于操作，无需积累经验或提前培训
- 快速监测设备状态，并在影响生产前快速识别设备问题
- 实时反馈振动和温度测量数据
- 利用 app 中的 SKF Pulse 检查功能可申请 SKF 专家分析、建议和诊断报告

I | TLDD 数字化机电式单点自动润滑器



即插即用系统

• TLDD 无线润滑器 (硬件)

提供电池供电的电动 TLDD 润滑器，预充两种规格的 SKF 润滑剂 125 毫升和 250 毫升，并且使用相同的驱动装置。润滑剂分配率可自由设定为 1 到 12 个月将罐内的润滑剂排空。可以采用 SKF DialSet 软件根据您的轴承和工况来计算润滑剂排空速度。

• TLDD 通讯网络

TLDD 通信利用低功耗广域网 (LPWA), 将无线润滑器连接到 SKF 润滑器监控平台。运营前两年，全面互联互通已包含在产品采购中。

• SKF 润滑器管理及监控平台

SKF 润滑器监控平台是此 TLDD 系列的最大优点。该应用管理平台以数字仪表盘的形式显示所有连接润滑器的实时状态，使您能够及时采取行动。

每个润滑器具有独立的润滑器标号 (Device-ID)，使您能够准确地识别润滑点及其相应的润滑状态。



I | BOPET 生产线的专用触媒及服务

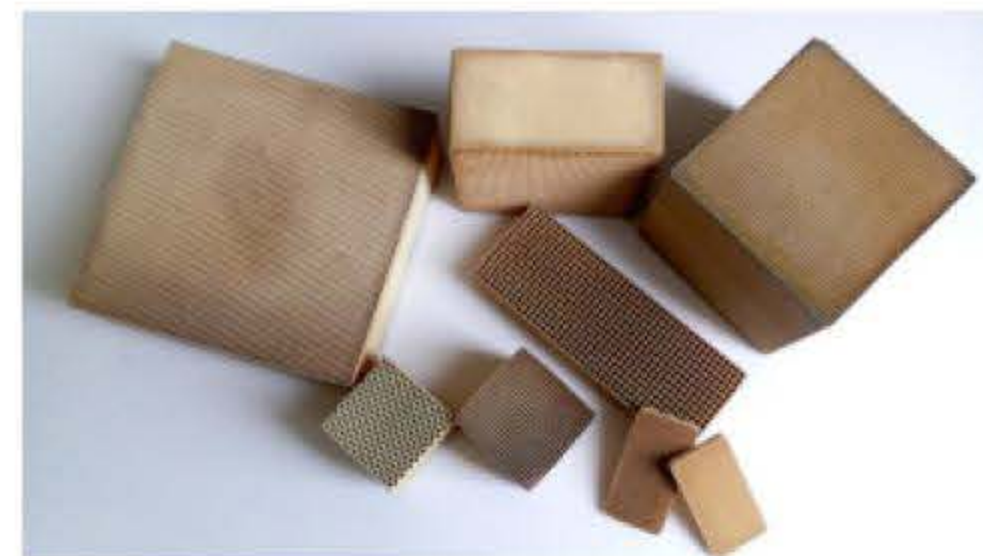
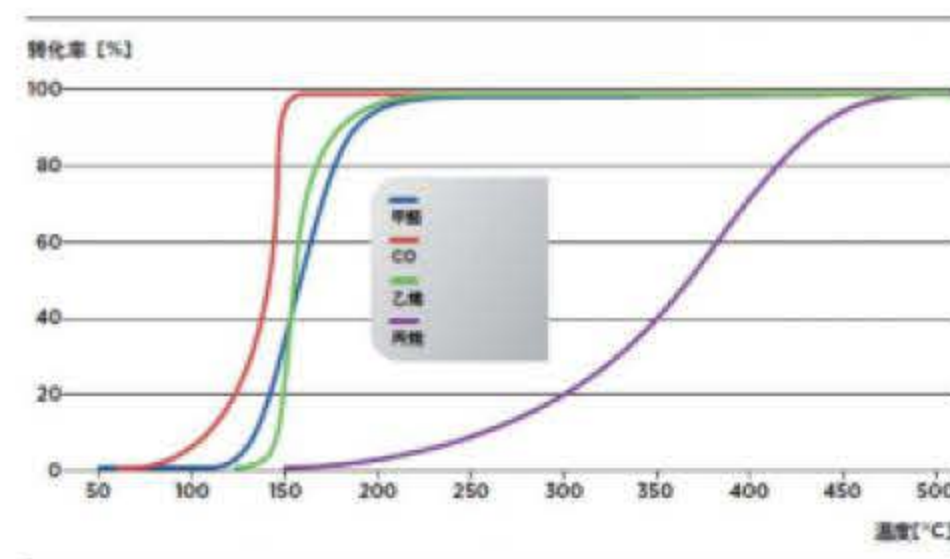

薄膜触媒应用与回收

• 触媒优势

低温性能好	降低成本	效果好	系统完整	抗毒性好	业绩突出
· 触媒低温性能好，能够在低于 200°C 有很好的处理效果	· 高温段气体温度无需加热，降低运行成本	· 处理效果好，满足高品质产品要求	· 无须对系统设备改造，保证系统完整性	· 特殊涂层设计，抗毒性能好	· 应用业绩多，德国薄膜线上都是安装我们的触媒

• 相关服务

- 1、我们免费提供 TDO 触媒的前期设计方案等技术服务
- 2、我们同时提供失效贵金属触媒的回收服务和以旧换新服务

静电丝 静电钢带

BOPET 生产线的专用易耗品—静电吸附丝 / 静电吸附带为公司的特有成熟产品，国内产线使用已超 70%。

一、钢丝钢带的母盘全部采用原装进口的知名品牌，国外工厂无尘车间加工，全程无毛刺检测，质量保证。

二、根据静电钢丝钢带的性能特点及客户不断提高的使用要求，结合超二十年的分装绕制经验，我们专门定制了国内唯一的高精度全自动专业级绕丝绕带机，保证绕丝不打结，绕带整盘端面平整，极大提升供货质量。

三、对比设备原厂及国内供应商所提供产品，明显减少放电次数及断丝断带现象。



国内其他普通厂家

涌泉出品

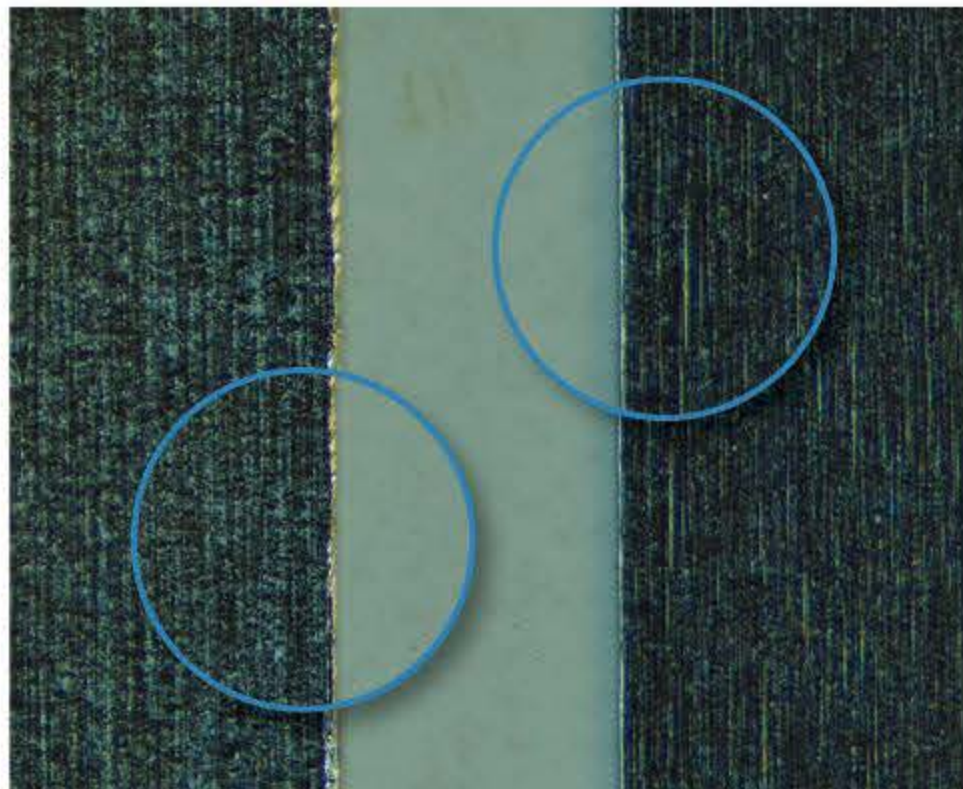

国内其他普通厂家

涌泉出品

铜丝棉 铜丝网

提供全系列黄铜丝、紫铜丝、紫铜网等清洁产品、辅助产品，本公司已是全行业此系列产品最大源头供应商，年销量超万包。



II TDO 幅宽计数器

打破国外垄断，打破超高价销售，投巨资全自主开发新品，完全替代原装进口。我们的产品
开发思路是所有零件采用的原材料等级均高于原装件一级，加工精度相应提高。

目前产线上正常使用已达三年以上。

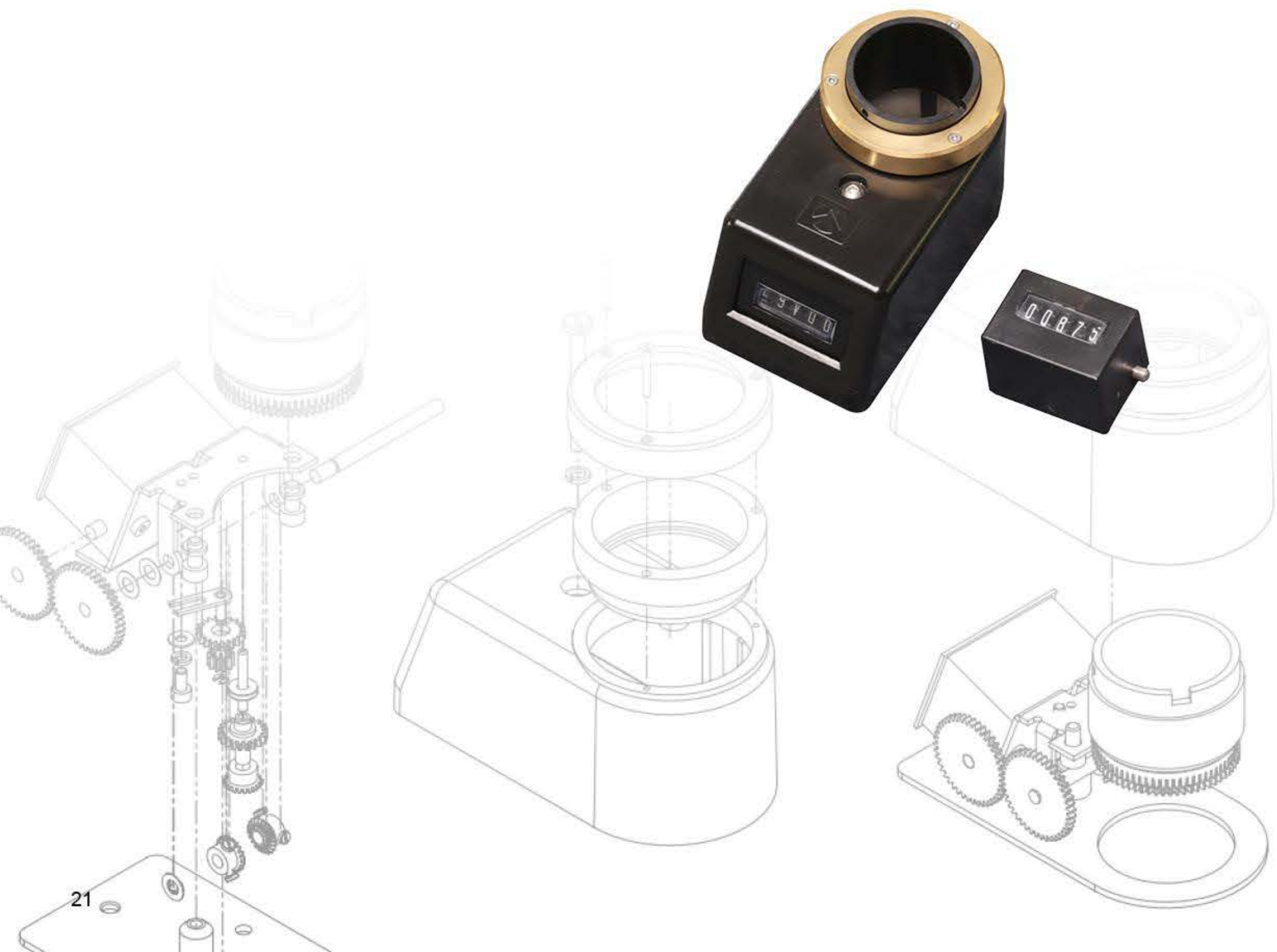

II 静电钢丝钢带收放卷装置

为适应 BOPET 生产线静电贴附，我们全自主
开发，其中关键元器件采用进口高端品牌，已有多
套上线在用，6 年以上应用实绩。

同时提供国产替代静电高压电源，或原装德国
进口高压电源。

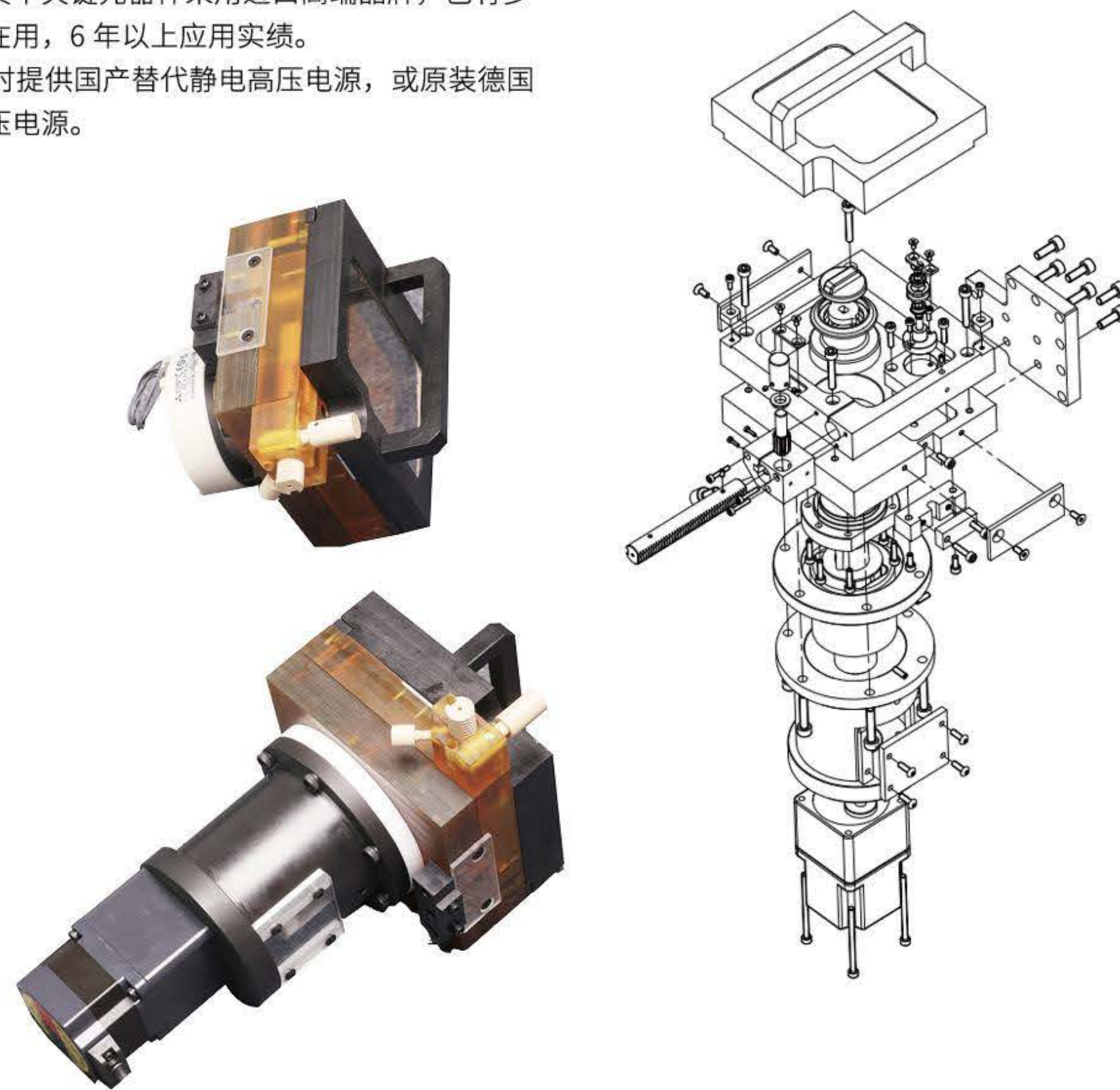

|| BOPET 生产线 TDO 余热回收

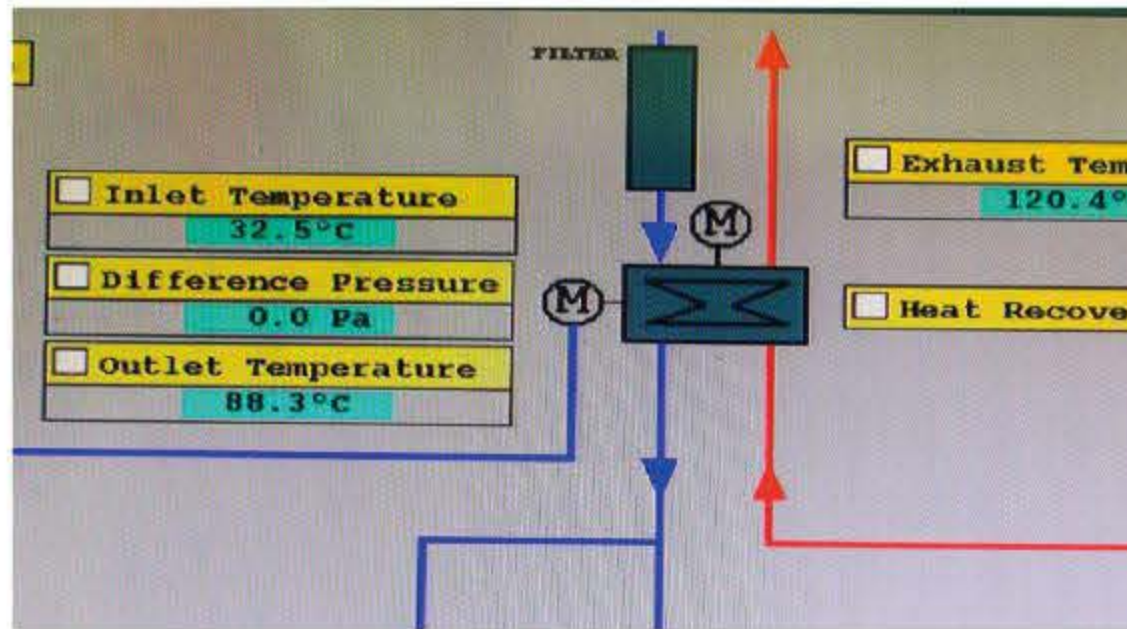

· 系统优点

热回收效率高

- 新风夏季温升 50+
- 冬季温升 70+

降低成本

- 一年节电超 100 万元
- 投资回收期 3-4 个月

通用性

- 解决低聚物堵塞问题
- 可新增或原转鼓拆除

业绩突出

- 在多家膜厂成功使用

· 相关服务

- 1、我们免费提供 前期设计方案等技术服务支持，后期的安装指导或总包
- 2、提供生产线的大修及技改服务

在双向拉伸聚酯薄膜 (BOPET) 装置冷却区里出现的白色粉末 (低聚物) 落到产品上会影响产品质量与价值。为了防止此问题发生, 一般采用方法是将装置内被污染空气排出, 再将新鲜空气送到炉内。但是, 只用此措施满足不了高品质产品要求, 而且新鲜空气加热也会增加能源消耗。分子量较高的低聚物在定型区等高温作业区里为气体状态存在, 但是一旦进入到冷却区受冷后形成白色粉末, 会附着到炉内腔体表面。随着生产时间的推移, 白色粉末积蓄到一定量后掉到薄膜上, 从而导致产品质量波动出现异常。通过余热回收, 从而加大炉内排风量, 我们可以达到以下效果:

1. 降低炉内清洁频率以及时间

由于低聚物浓度大幅降低, 炉内的污染也减少。可降低由清洁炉内所产生停车的频率以及时间。

2. 节省能源

由于利用我们的余热回收装置, 热回收效率可以 70% 及以上, 将排气通过热交换器进行热回收也很有效。但以前的转轮式热交换器因为通气孔细长会被低聚物污染堵塞, 基本不到一年换热系统就完全失效。而我们的余热回收系统是采用更成熟的热管换热, 完全阻隔了转轮热器新回风间的低聚物传输; 并创新式在热管热端做特殊涂层处理, 防止低聚物凝聚在翅片表面从而降低换热效率, 只要做定期吹扫。

3. 投资成本低, 投资回收比高

生产线如采用贵金属触媒, 一条投资 120 万以上, 可以解决部分低聚物问题, 降低了排风量, 同时也可以节省能源, 但触媒有个致命缺点就是会中毒, 从而面导致失效。另一个就是生产线原配的转轮式热器, 一是容易堵, 很快失效, 同投资成本高于我们的热管热器, 并不能隔绝新回风间的污染问题。

经测算和实际应用, 我们的热管换热器投资回收周期约 3-4 个月, 一台换热器年节约电费金额百万以上。

联合开发红外管

本公司与外国知名公司合作联合开发红外管，可根据被加热材料的特性进行设计，采用材料可吸收的红外线波段峰值时的射线，对材料进行能量吸收最大化的加热，以最小能源实现最佳加热效果。

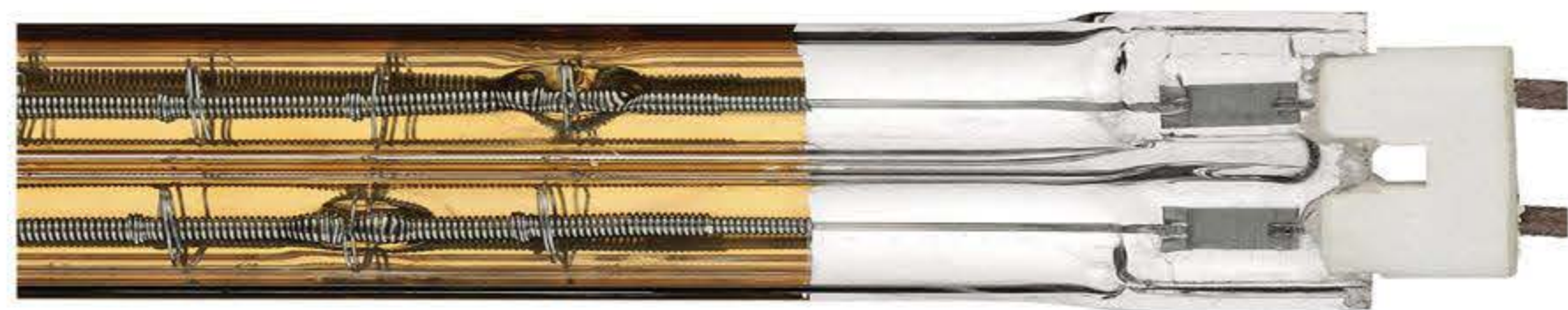

· 红外快中波石英辐射器的主要特点：

双孔管标准横截面 34x15 mm

射线峰值范围 1.4-1.6 μ m

最大功率 50W/cm

最大单位面积功率 130kW/m²

水平工作，也可根据需要设计制造垂直使用的辐射器

可在石英管上添加反射涂层，更有效地将光波能量聚焦

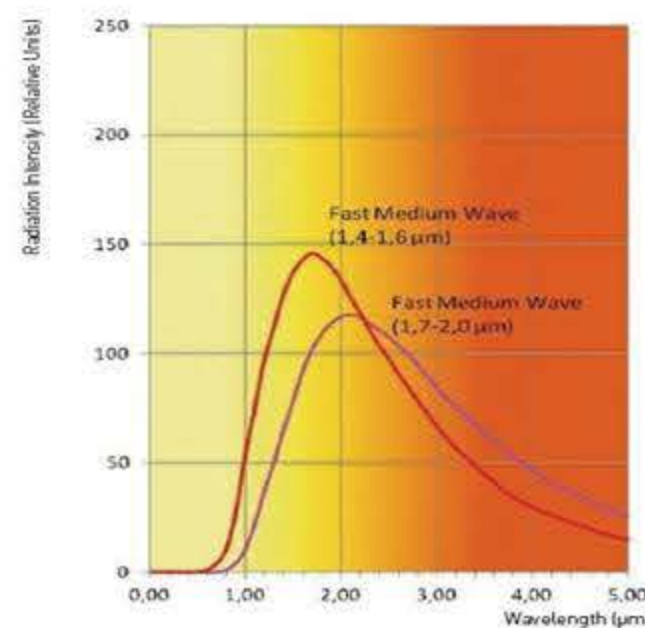

红外快中波石英管

· 红外灯管常备规格表

1500mm*1400mm*13KW 380V	1650mm*1500mm*12KW 400V	1800mm*1600mm*9500W 380V
2060mm*1980mm*11.088KW 500V	2120mm*1980mm*15KW 400V	2220mm*2100mm*14870W 380V
2220mm*2070mm*15.1KW 380V	2250mm*2130mm*15KW 400V	2350mm*2250mm*15KW 500V
2400mm*2250mm*11KW 400V	2400mm*2100mm*14KW 400V	2820mm*2720mm*15KW 400V
2800mm*2680mm*14880W 500V	2920mm*2800mm*17.5KW 400V	3320mm*3200mm*14KW 380V 半镀金 线长 3100

涌泉投资企业

安徽煜卓机械有限公司是一家深耕固废破碎装备研发与制造的国家高新技术企业，以“创新驱动绿色发展”为使命，聚焦固废资源化领域智能化装备研发，构建起覆盖研发设计、智能制造、系统服务的全产业链能力。公司总部位于“中国刀具之乡”安徽马鞍山市博望区，2024年战略布局南京溧水智能制造基地，形成“双核协同、辐射全球”的产业版图，现已成为国内固废处理装备领域技术领先的创新型标杆企业。



薄膜破碎机主轴转子修复 (安徽工厂业务)

破碎机在平时使用中由于各种因素会导致转子损坏，对生产影响很大，客户往往很着急。为此我公司自营工厂专门开展了转子修复业务，主打高效、可靠，为客户分忧解难。

我公司还可按客户要求定制各类破碎机。



·修复步骤

确定分析测绘所需修复的区域的所需的钢材尺寸，第一时间快速采购，并绘制修复区域部件粗加工图纸。

将清理打磨好的转子吊到数控四轴加工中心，进行端面铣削，铣出基准面。开出焊接坡口。

按照修复区域部件粗加工图纸，加工好零部件。将转子和加工好的零部件进行点焊铆接，确定焊接是否正确。对转子预热用对应的焊材进行快速焊接一次性成型。

再将转子吊到动平衡机，进行动平衡检测。（按动平衡 G6.3 等级）保证转子的稳定性。

将车好的转子再次用四轴加工中心精铣刀片按照平面，并加工刀片固定孔，并打磨去毛刺，（加工刀片固定孔要做专用工装）

将焊接完成的转子，用数控车床进行外圆修复。保证外圆同心。

BOPET生产线特供备件



BMS 静电钢带

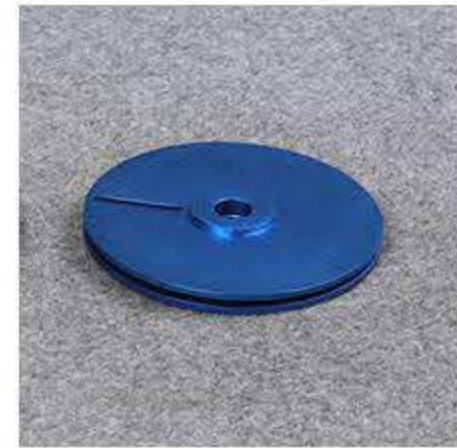

多尼尔静电钢带

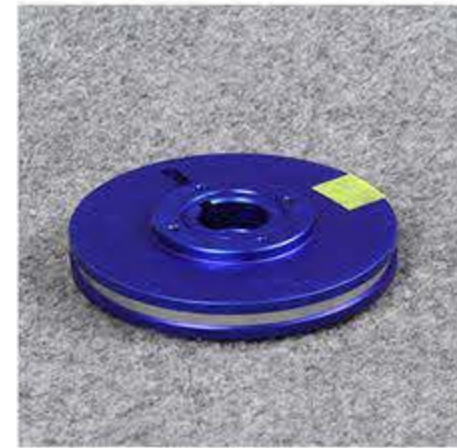

多尼尔静电钢带



MEK 静电钢带



静电钢带



静电吸附丝



静电吸附丝



静电吸附丝



静电吸附丝



静电吸附丝 0.4



美国线静电丝

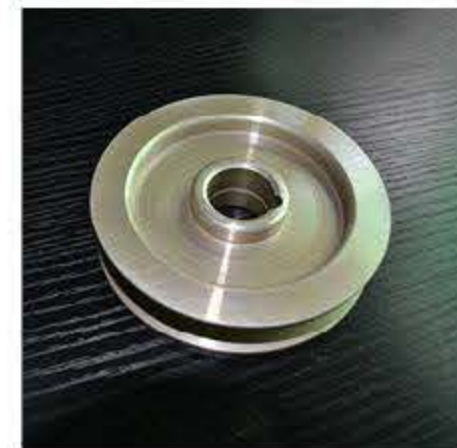

东丽静电丝

BOPET生产线特供备件



静电钢带

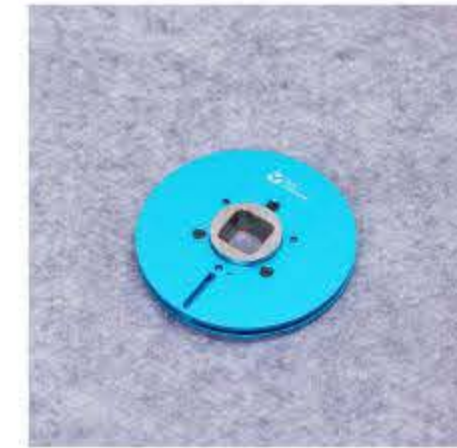

静电钢带

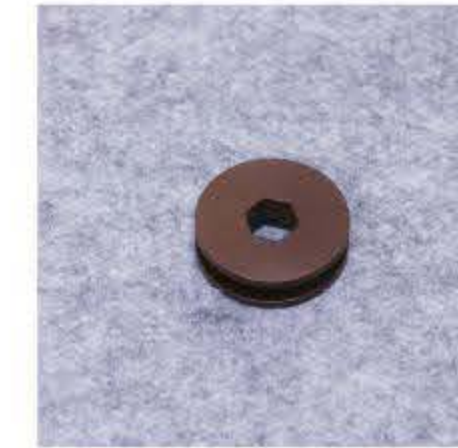

静电钢丝

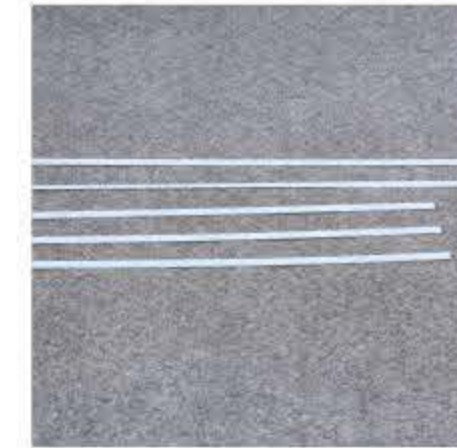

多尼尔静电套管



静电套管 1.2/2.0



静电套管



压边喷嘴



静电绝缘柱



静电吸附绝缘座



吸附系统配件



红外弯管



静电高压发生器

挤出及模头清洁等备件



不锈钢金属 O 型圈



不锈钢空心 O 型圈



各种熔体铝密封圈



各种熔体铝密封圈



铝垫片



垫片



铝密封圈



铝密封圈



方型铝圈

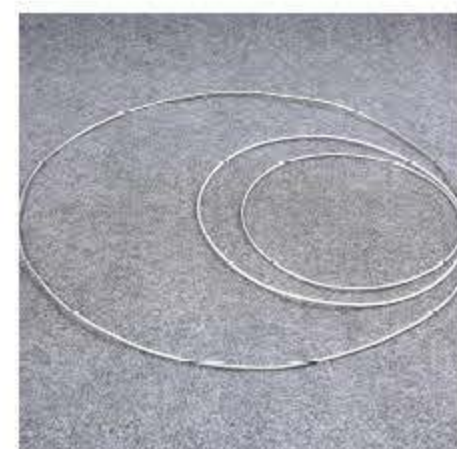

铝密封圈



导流头



导流头

挤出及模头清洁等备件



附挤过滤器滤网



附挤过滤器底座滤网



水槽密封环



石墨环



石墨环



石墨环

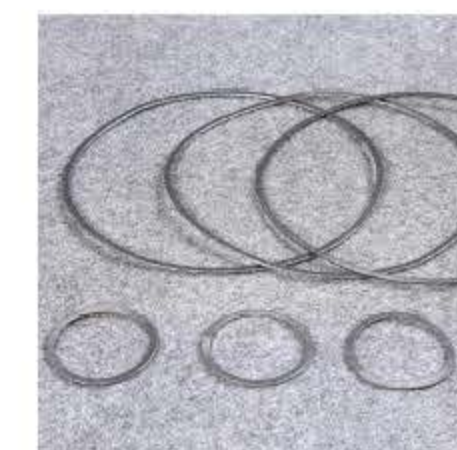

石墨密封圈



熔体密封



熔体密封



熔体密封



熔体密封



灯管支架

挤出及模头清洁等备件



滤袋压块



真空过滤袋



硅油



雾化硅油



楔形塞尺



铜塞尺



铜丝球



紫铜棉



黄铜棉



紫铜网



紫铜球



紫铜棉

挤出及模头清洁等备件



模头调整螺栓组件

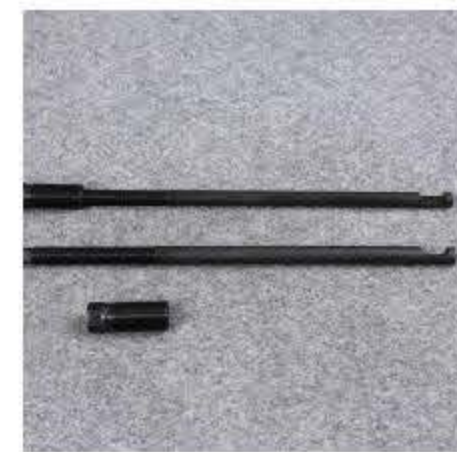

模唇调节螺栓螺母



模唇调节螺栓



模头螺栓 M14-1.2



研磨膏



铜丝刷



铜丝刷

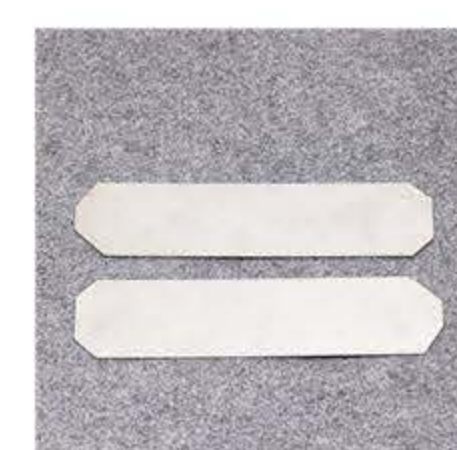

模头侧封板



模头侧封板

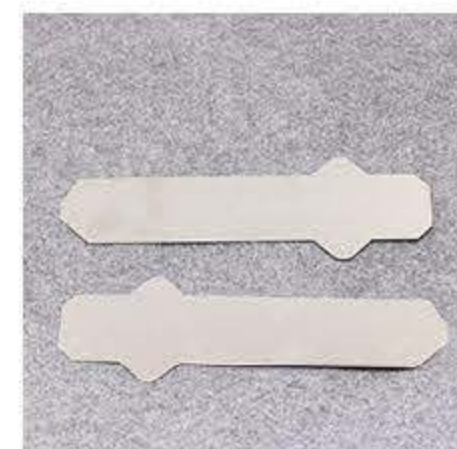

模头侧封板

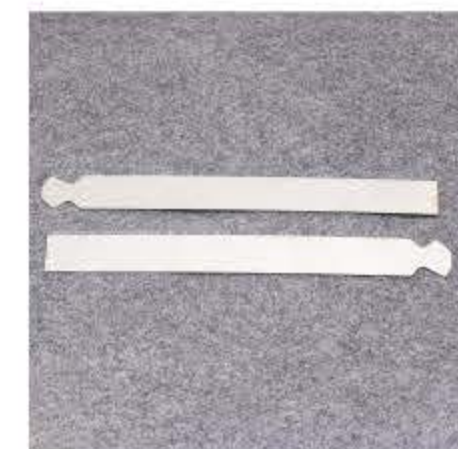

模头侧封板



模头侧封板

挤出及模头清洁等备件



模头螺栓专用扳手



模头清洗皂



铜基防紧蚀膏



空气喷管



不锈钢空气喷管



空气喷管



铜刀



模头螺栓加热棒



活动拉杆

TDO专用配件



M10 M12 自锁螺母



齿形销



多尼尔链节



钢套



不锈钢挡圈 80-41-8.5



轴承挡油圈



隔垫



进口 DU 轴套



进口 DU 轴套



进口轴套



链夹滑块



开口销 (卷销)

TDO专用配件



卡簧



链节链片



链条垫片



TDO 开夹块



PEEK 滑块



链条及配件



轴承挡油盖



轴套 PEEK



厚垫片 $\Phi 21.5-12.6-6$



垫片



自润滑垫片



防滑垫片

TDO专用配件



链夹防松垫片



防松垫片 $\phi 26-10.5-1$



链条垫片



PEEK 垫片



不锈钢垫片



耐磨垫片



铜垫片



调整垫圈 8.2-12-4.8-4.5



垫圈 M22-15.4



轴承挡圈 厚 9



轴承挡圈 厚 5



多尼尔链夹轴销

TDO专用配件



滚轮轴 I



夹柄销 12-69



夹柄销 12-108



链夹固定螺栓



链夹夹柄轴销



链节轴销



链条销轴



链条销轴



链条销轴



轴销 φ35-171



轴销 φ12-121



轴销 18-81.2

TDO专用配件



轴销



轴销



轴销



轴销



轴销 18-81.2



轴销 20-84.5



链夹固定螺丝



TDO 入口展平辊



PEEK 长条滑块 50-10-8

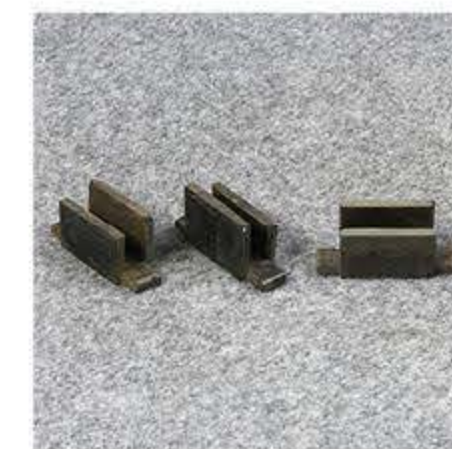

U形滑块



方形滑块



圆形滑块

TDO专用配件



DMT 链夹 U形滑块



内六角法兰螺栓



内六角螺栓 M8-105



外六角法兰螺栓



内六角螺栓



外六角法兰螺丝 M8-90



螺栓 M10-97.5 右旋



蘑菇头螺丝



蘑菇头螺丝



尼龙开夹块



TDO 开夹块



TDO 链条档条

TDO专用配件



闭合器 300-140-38



垫板 10-50-500

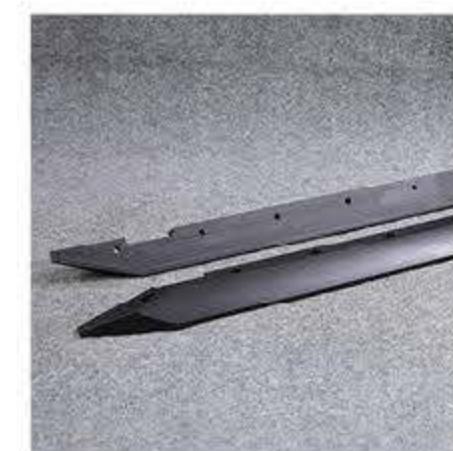

垫板 40-55-882



进口开夹板



开夹板 18-33-340



开夹块 350-191-35



开夹盘 500-100-23.6



开夹片



气嘴固定座



TDO 入口开夹盘
400-261.5-25



TDO 转盘弹簧片



平垫

TDO专用配件



玻纤弹簧密封条



发泡硅胶条



发泡硅胶条

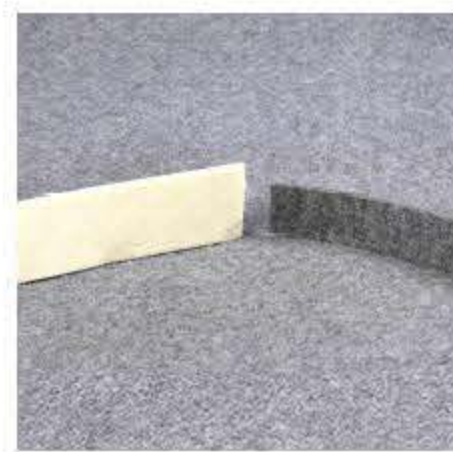

毛毡条



门框密封条



高温油管



油管接头



油管接头



8字形门框密封



V键



鹰嘴垫片



轴销锁片 96-25-4

TDO专用配件



链夹顶轴座



链夹顶轴 19-15-27



链夹顶轴螺丝 M20-1-26



轴承底座螺丝



耐磨铜销



推力块 PEEK



推力块 铁



弹簧底托



BMS DMT 多尼尔等夹柄备件



BMS DMT 多尼尔等夹柄备件



链夹



FOK444 链夹

TDO专用配件



三菱线链夹



三菱线链夹



DMT 链夹



BMS DMT 多尼尔等夹柄备件



调幅螺母

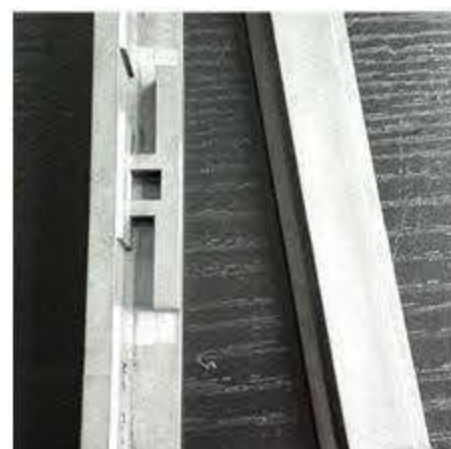

TDO 滑块

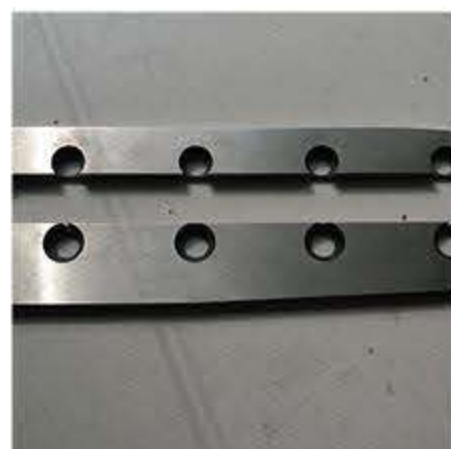

TDO 导轨



TDO 链条定制



弹簧销



SKF 喷油单向阀



喷油针



链夹胶垫

TDO专用配件



夹柄弹簧



夹柄弹簧销



链夹弹簧套



链夹弹簧套



挡油板



挡油板



幅宽计数器



幅宽计数器



强力磁铁



触媒框架



幅宽调整扳手



黄铜油嘴

阿托拉斯、康普、格贝尔分切机等专用备件



3寸被动卡头



3寸被动卡头 ATLAS



3寸分切卡头老康普



3寸分切卡头单排新康普



3寸分切卡头 新康普 单排



3寸分切卡头新 ATLAS



3寸分切卡头新康普



格贝尔分切卡头



6寸被动卡头



6寸分切卡头单排康普



6寸分切卡头老 ATLAS



6寸分切卡头老康普

阿托拉斯、康普、格贝尔分切机等专用备件



6寸分切卡头新康普



C3 被动卡头



C3 主动卡头



分切卡头重型



2T 3T 5T 同步带轮轴



AT1025T 同步轮



HTD8M-29T-51.5BF 同步轮



同步轮



ATP10 带轮



ATLAS 带轮轴



同步轮 8M-28T-39AF



同步轮 8MGT-26Z

阿托拉斯、康普、格贝尔分切机等专用备件



同步轮 8MGT-31T-69



同步轮 P28-8M-AF



同步轮
28-8M-42BS-DF42.36.27



同步轮 8M31T040Z62(40Cr)



键条



ATLAS 收卷轴



格贝尔收卷轴



老 ATLAS 卡头轴



老康普分切轴带花键



新 ATLAS 分切轴芯



工位轴承座 33.5-89-59



老康普重型分切轴芯 151.5-65

阿托拉斯、康普、格贝尔分切机等专用备件



卡头凸轮轴 D6H5-32.5



卡头凸轮轴 79-260.7-30



卡头凸轮轴 153-79



工位轴承座垫片



同步带轮安装座



轴承座 25-115-50



工位压辊气缸



工位轴承座 23.5-110-62



工位轴承座 20-110-56



压辊轴承座 42-132-53



压辊轴承座 60-36



轴承座

阿托拉斯、康普、格贝尔分切机等专用备件



康普分切工位纸管托架气缸



压辊气缸



胶木齿轮带铁芯



胶木齿轮斜齿



胶木齿轮直齿



胶木齿轮固定轴



胶木齿轮内芯 47.5-135-31



胶木齿轮皮带固定轴

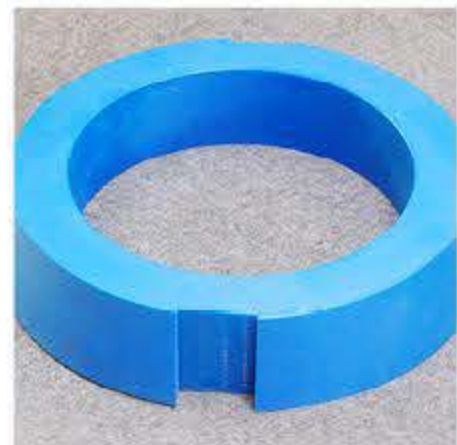

放卷卡头耐磨块 $\Phi 433.730088$



放卷卡头耐磨块 380-330-85



放卷耐磨块



胶圈

阿托拉斯、康普、格贝尔分切机等专用备件



胶圈



胶圈



接头



金属接头



快速接头



刹车片



涨紧轮



过渡套 32-65-35



ALAS 分切工位联接



齿轮心部套 45-120-60



齿轮心部套 56-120-32



弹簧气管

阿托拉斯、康普、格贝尔分切机等专用备件



弹簧片



卡头弹簧

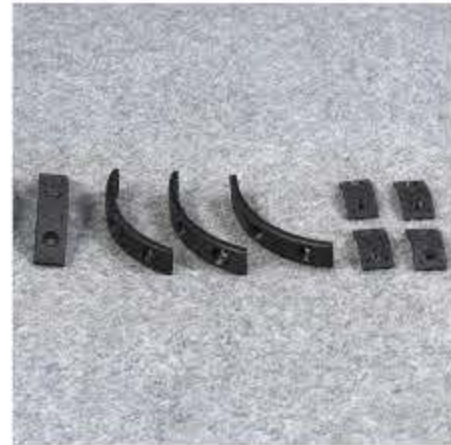

分切卡头耐磨块



分切卡头滑轮



卡头固定块



压块 25.3-20.4



分切卡头滑舌片



工位移动电机



离合器片



联轴器



锁紧齿轮含涨套



压辊臂

阿托拉斯、康普、格贝尔分切机等专用备件



压辊轴头



ATLAS 分切工位联轴器



ATLAS 工位压辊气缸
(双作用)



分切机圆刀架 (ATLAS)



康普圆刀架及配件



圆刀架及配件



方型刀架



气管接头 (圆刀架配件)



卡头凸轮



胶木齿轮内芯



滑块包胶



重型卡头滑块

阿托拉斯、康普、格贝尔分切机等专用备件



3寸卡头滑块



卡头滑块



卡头凸轮 3寸老 ATLAS



卡头凸轮 3寸老康普



卡头凸轮 3寸新 ATLAS



卡头凸轮 6寸老 ATLAS



卡头凸轮 6寸老康普



FIFE 导边探测器



软膜带 50*1.5

盖茨、麦高迪、OPT等进口同步带/三角带/平皮带/多楔带及配套同步带轮、弹性块

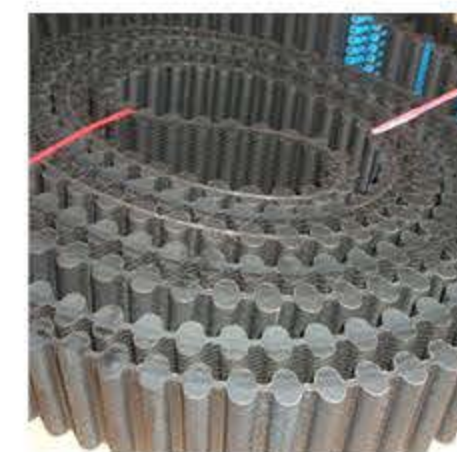

盖茨、麦高迪、OPT等进口同步带/三角带/平皮带/多楔带及配套同步带轮、弹性块



隔震垫

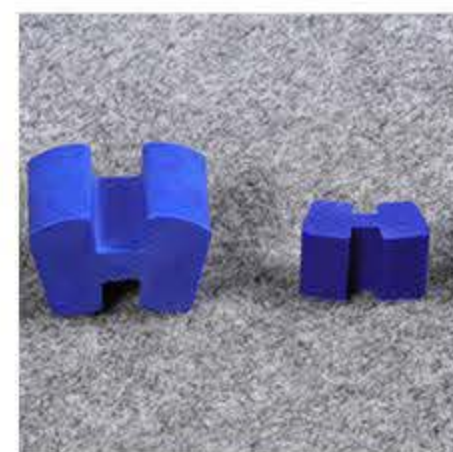

H型弹性块



弹性块



鼓形垫



减震胶

测厚仪、电晕专用备件



包胶轴承



测厚仪包胶滚轮双轴承 608

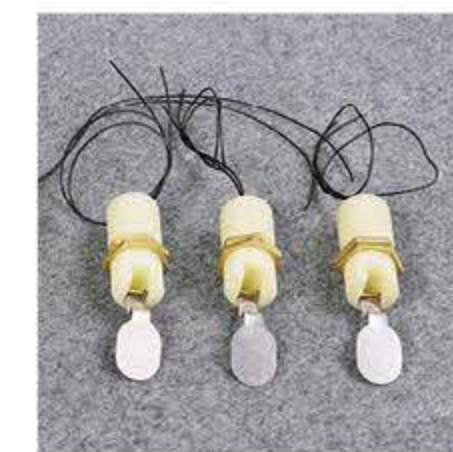

电晕风量开关



电晕磁瓶



电晕电缆



带轴承滚轮



硅胶密封胶



测厚仪行走导轨改造



排臭氧软管



高温吸料软管



导向轮



测厚仪滚轮

分切机、收造粒设备上用的破碎刀片/滚刀/定刀/三孔刀等备件

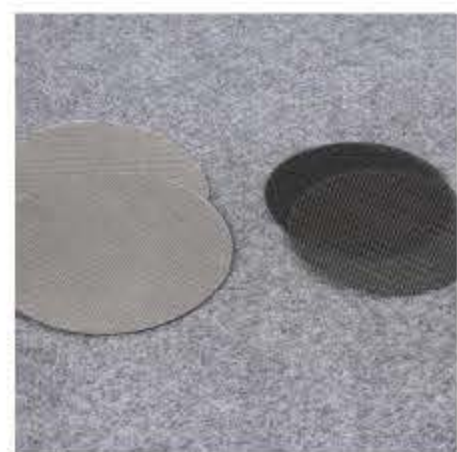

过滤网



合金三孔刀片



螺丝 14-1.5-50



破碎机刀片



切边刀片

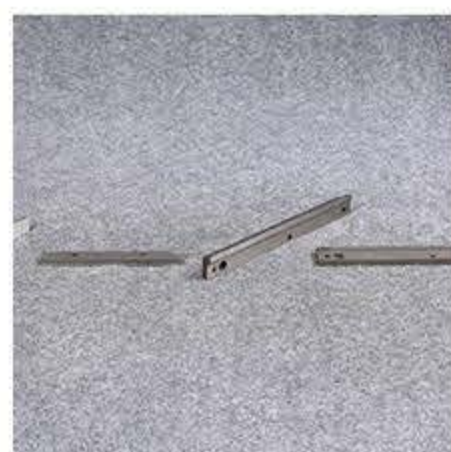

切边刀片



切割压实刀片 129-30-5



切粒机刀片



切粒机小铲刀



撕碎机刀片



撕碎机刀片



撕碎机刀片

分切机、收造粒设备上用的破碎刀片/滚刀/定刀/三孔刀等备件

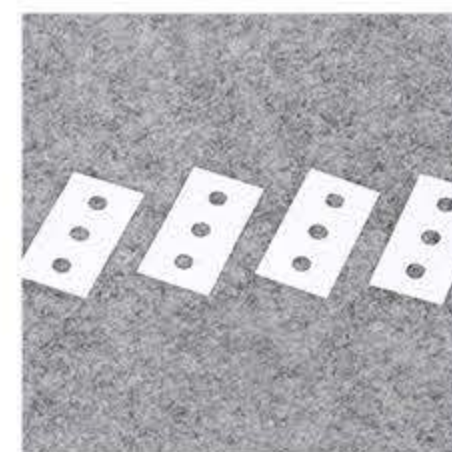

陶瓷三孔刀片



切粒机定刀片



破碎机刀片



圆刀片



圆刀片



钩刀



风管卡箍密封条



陶瓷及钨钢定刀



陶瓷刀片

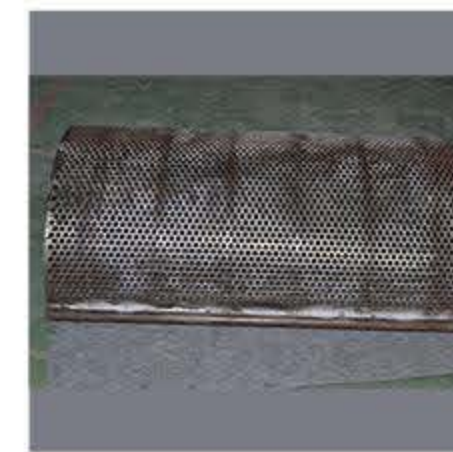

破碎机筛网



切粒机用胶木齿轮 Z=90/95 等



切粒机滚刀

通用机械类配件



DN80 机封



机械密封



机械密封



机械密封



机械密封



水泵机械密封



旋转机头机封



旋转接头机封



旋转接头机封



旋转接头机封



真空泵机封



进口导热油机封

通用机械类配件



联轴器膜片



联轴器膜片



石墨轴承



收卷钢芯活动爪



直角连杆



收卷机钢芯爪轴 33-89



RTK 齿轮



丝杆螺母



锁紧盘



温度传感器护套



飞刀导边



加热管支架

通用机械类配件



氟胶 O 型圈



高压单向阀



各型号十字轴承



压边轮



包胶压边轮 125-110-42



硅胶条



滤芯



球笼式万向轴



力士乐滑块导轨



油封



支撑座 6.5-33.7-35



KSB 导热油泵水泵

通用机械类配件



旋转接头



万向轴



万向轴



万向轴



板式换热器



金属软管



CBG 刮刀



perma 油杯



filtrec 油滤芯



perma 油杯



perma 注油器



skf 注油器

自控备件及力士乐气缸、FESTO、诺冠等气动产品、直流电机用罗兰碳刷



加热圈



加热圈



分切收边减速电机



熔温传感器



静电毛刷



气缸维修包



碳刷



碳刷



模唇传感器



温度传感器



模头螺栓陶瓷加热管



热电偶

自控备件及力士乐气缸、FESTO、诺冠等气动产品、直流电机用罗兰碳刷



RTK 阀门



RTK 阀门



RTK 阀门



SKB 阀门



PT100



PT100



罗兰碳刷



罗兰碳刷



加热器



加热器



EBM 风机



EBM 风机

自控备件及力士乐气缸、FESTO、诺冠等气动产品、直流电机用罗兰碳刷



力士乐比例阀



收卷出口安全垫



DMT MDO 导电环



镀铝机高温电极



施耐德继电器



DYNISCO 熔温熔压传感器



DYNISCO 熔温熔压配套仪表



IGBT 模块



水银接地环



西门子低压



西门子工控



ARI 电动执行器

自控备件及力士乐气缸、FESTO、诺冠等气动产品、直流电机用罗兰碳刷



ASCO 调压阀



CKD 气缸



E+H 料位计



FESTO 气缸



TDO 导边压力模块



百乐福气缸



富士变频器



富士变频器



高温接近开关



霍尼韦尔电动执行器



霍尼韦尔电动执行器



静电铜丝

自控备件及力士乐气缸、FESTO、诺冠等气动产品、直流电机用罗兰碳刷



力士乐气缸



诺冠气阀



气缸执行器



气缸



西门子辅助触点



西门子控制器



西门子电机



西门子电源模块



微压表



加热器

德国MAHR测厚仪及配件, FROMM打包机及配件等



生产线辅助配套设备



收卷卸卷小车



母卷辅助放卷小车



辅助收卷小车



模头拆装小车



三层模头拆装小车

更多产品与服务敬请期待

Stay tuned for more products and services